

**SECTION THRU WALL PANEL AND CONCRETE FOUNDATION**

T1

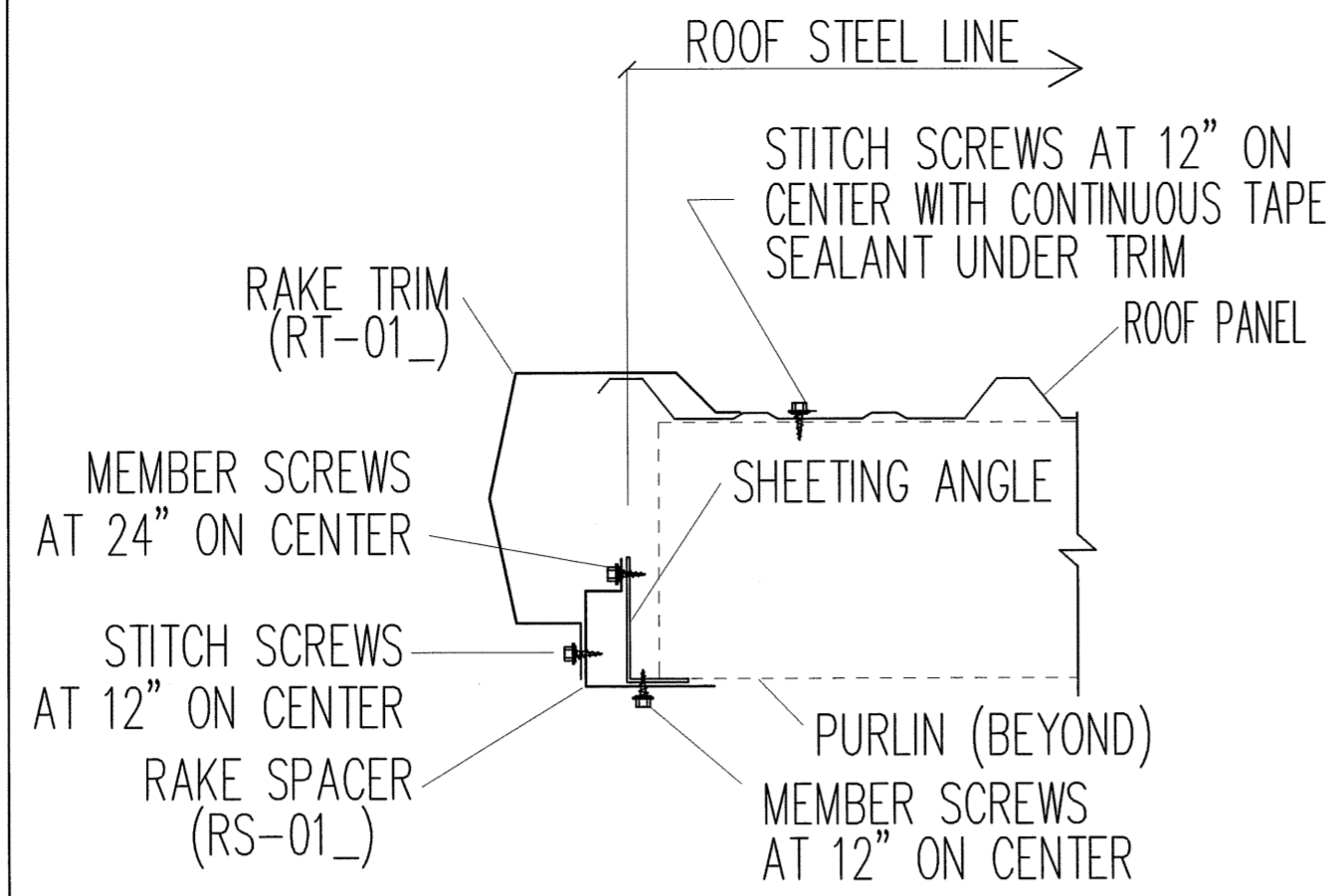

**RAKE DETAIL WITH OPEN WALL**  
("R" ROOF PANEL SHOWN, "M" ROOF PANEL AVAILABLE.)

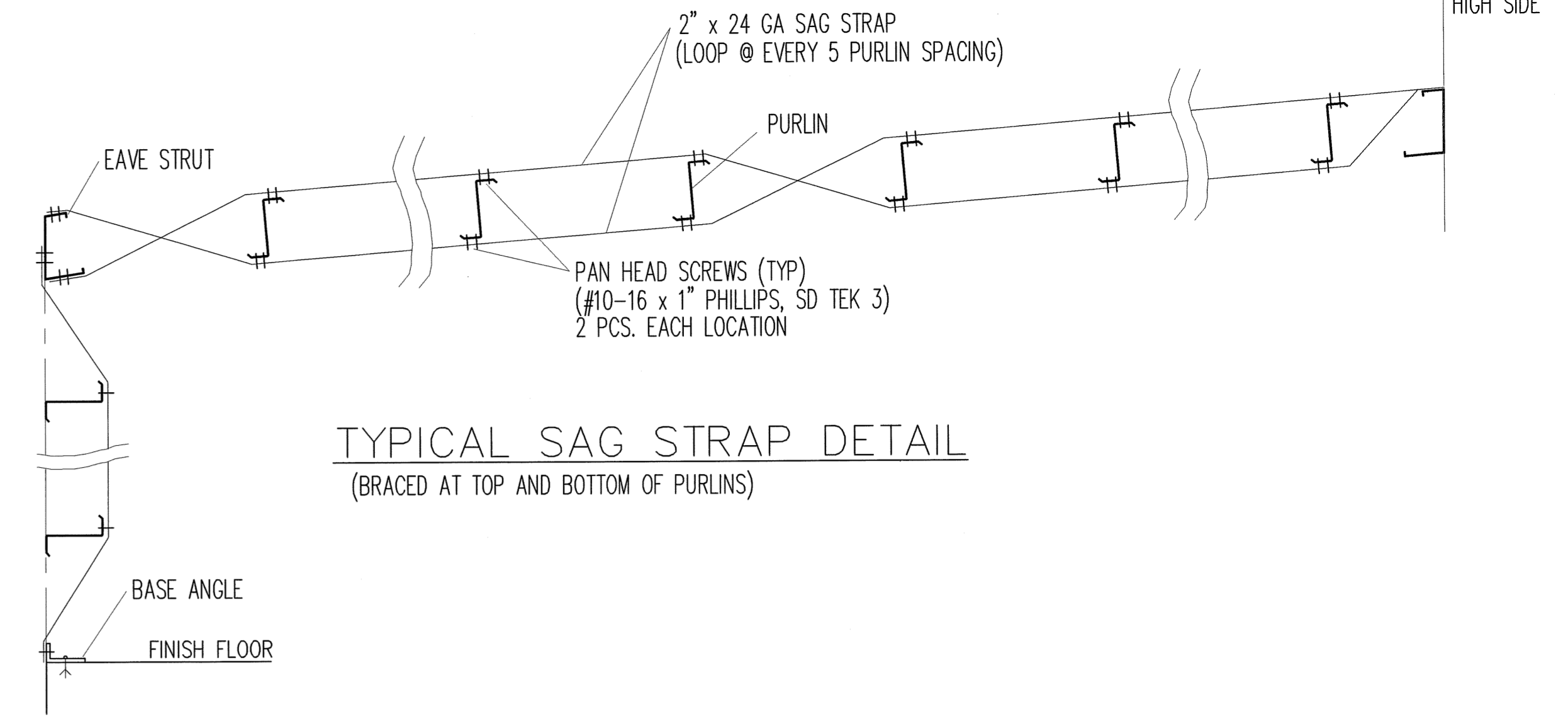

**TYPICAL SAG STRAP DETAIL**  
(BRACED AT TOP AND BOTTOM OF PURLINS)

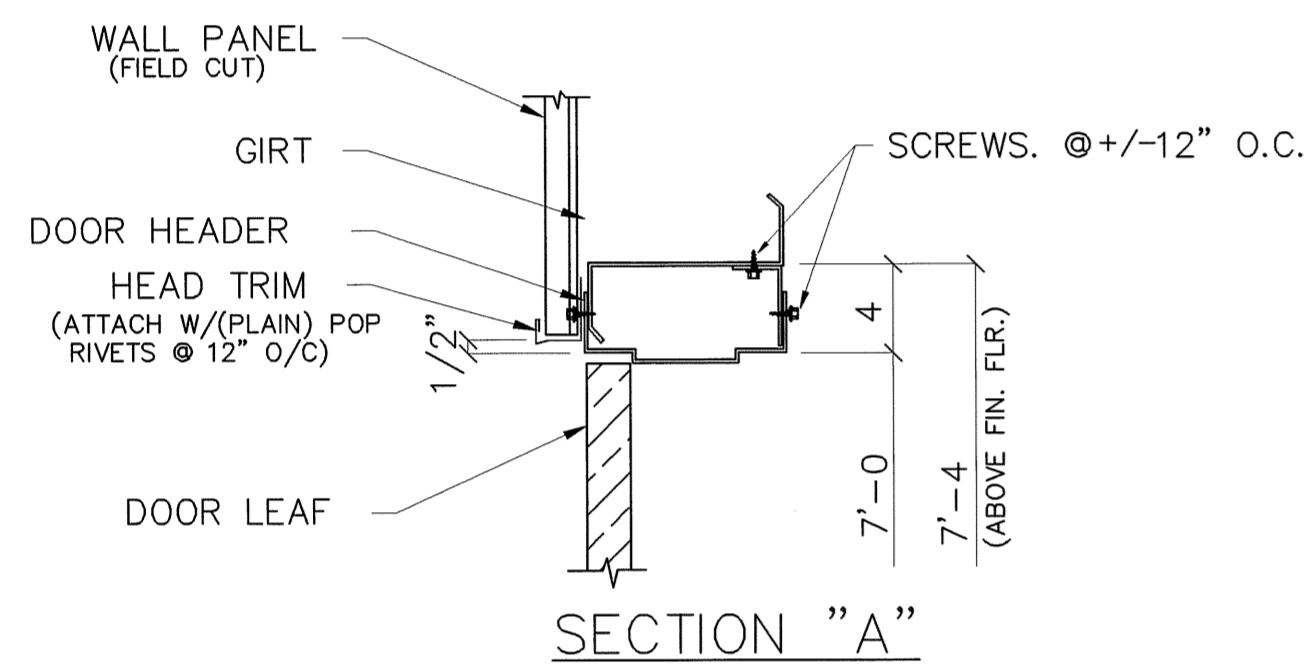

**SECTION "A"**

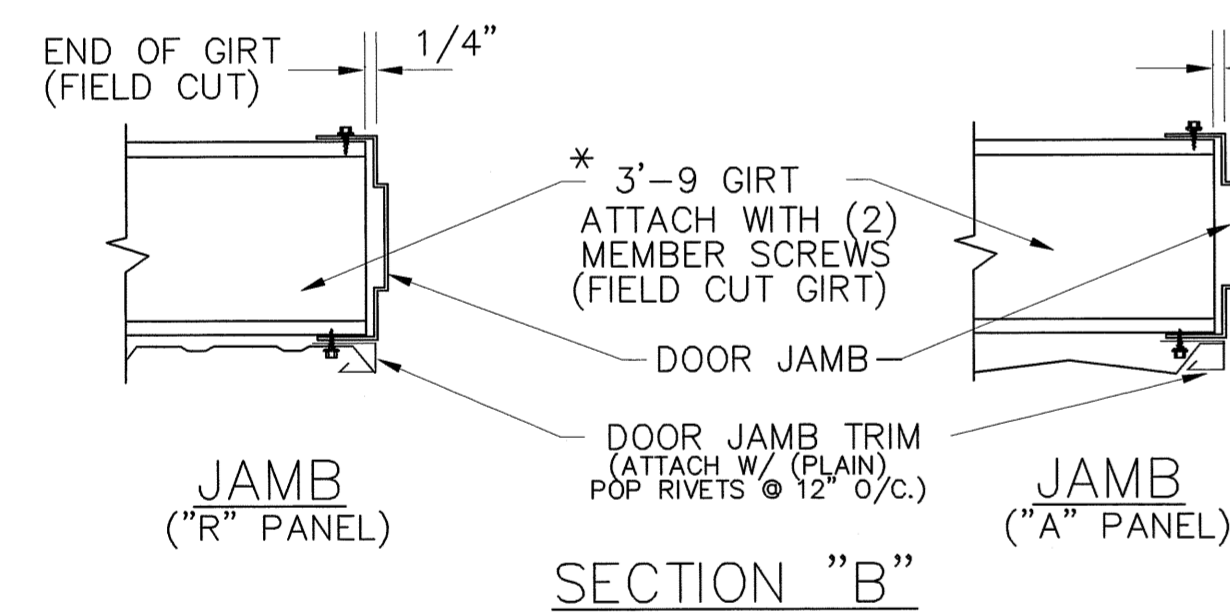

**SECTION "B"**

**INSTALLATION PROCEDURE**

1. Place head section and jamba on flat surface (floor) with door side up. Install bolts and nuts connecting head to jamba. Be sure that head is tight to jamba so that the proper door opening is obtained.
2. Install door leaf in frame, check for 1/8" clearance at head and 3/32" clearance at striker jamb.
3. Tilt up the entire assembly and anchor hinge jamb to floor. Plumb hinge jamb and assembly. Field cut girts if required.
4. Anchor head and striker jamb to building structure, floor and entire frame to panel skins (field cut). Install optional threshold anchor if desired. Install jamb extensions (if req'd).
5. Install lockset. Install (optional) weatherstrip, head member first. Adjust so that vinyl just contacts door when in the closed position. Do not force vinyl against door as this will interfere with the latching and will not improve the weather seal.

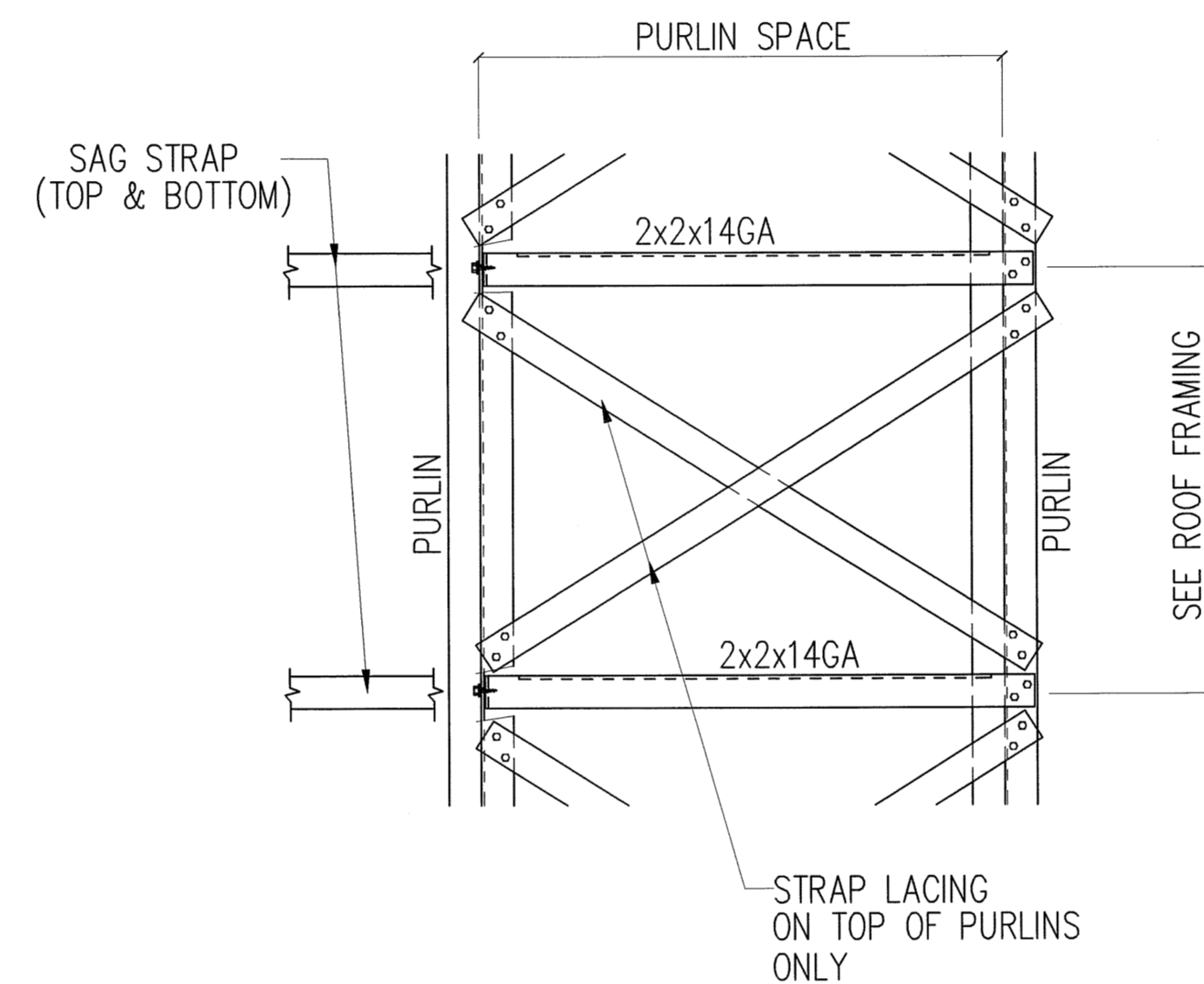

**PLAN**  
**QUEEN'S TRUSS DETAIL**

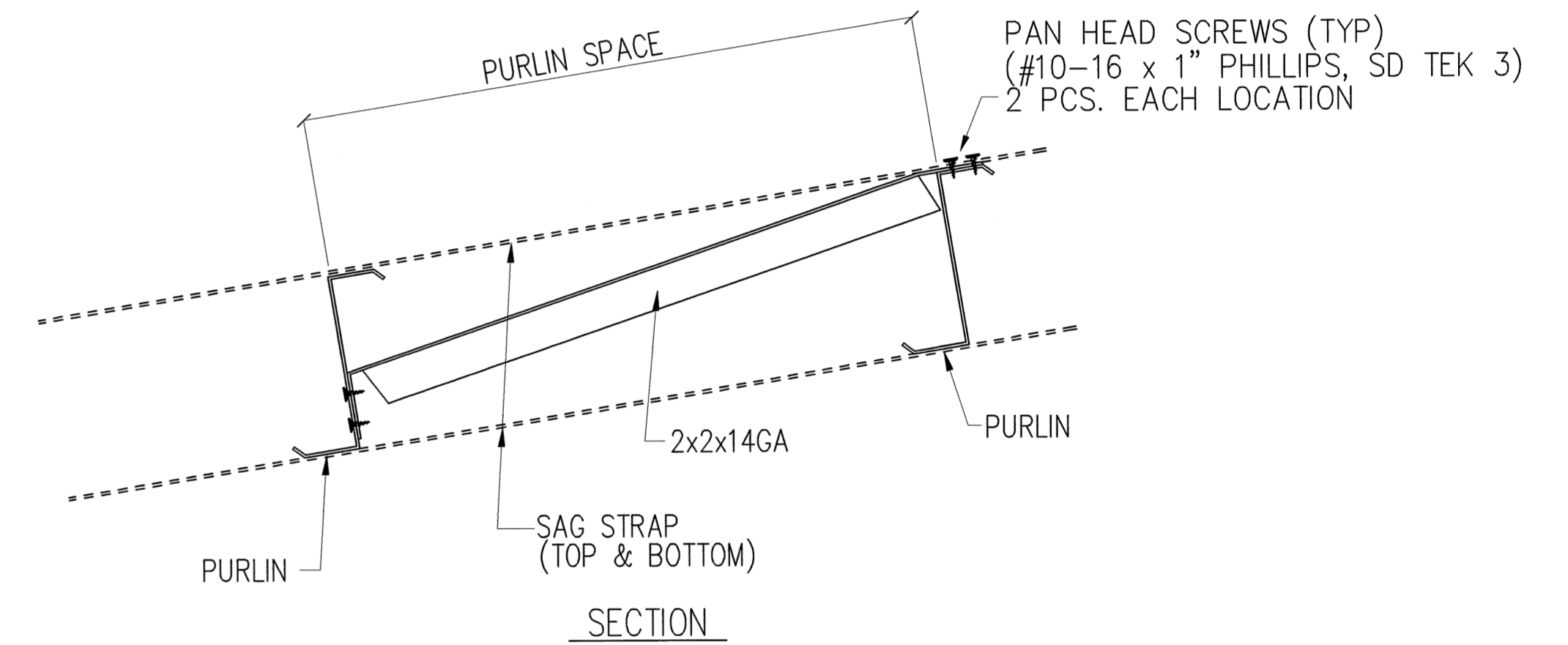

**SECTION**

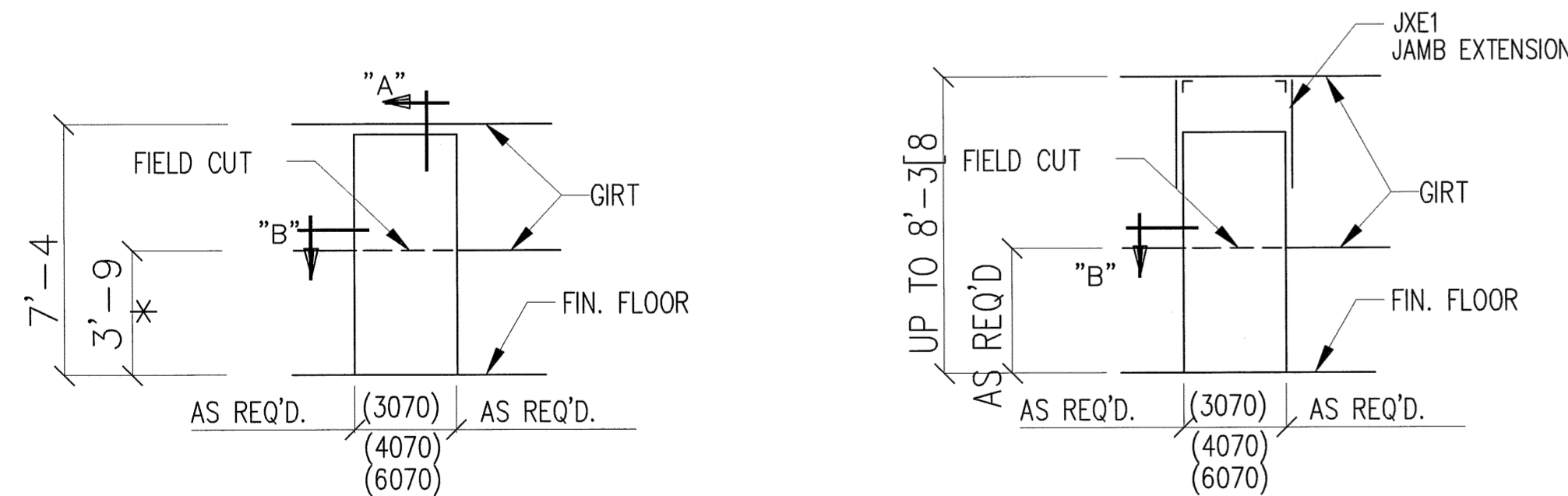

**FOR FIELD LOCATED WALK DOOR**

\* - 3'-9 GIRTS SUPPLIED ONLY WHEN REQUIRED BY DESIGN.

WALK DOOR  
FOR 3070, 4070,  
& 6070 ONLY

**FOR PERMIT**

JUN 10 2008

SEALING OF THIS DRAWING DOES NOT IMPLY OR CONSTITUTE THAT RIGID BUILDINGS ENGINEER IS THE ENGINEER OF RECORD OR THE DESIGN PROFESSIONAL FOR THIS PROJECT. ONLY THE DESIGN OF THE METAL BUILDING SYSTEM AS FURNISHED BY RIGID IS INCLUDED. FOUNDATION ANALYSIS, ELECTRICAL, AND MECHANICAL SYSTEMS, AND/OR OTHER PARTS SUPPLIED BY ANYONE OTHER THAN RIGID ARE SPECIFICALLY EXCLUDED. NO INSPECTION OR SUPERVISION IS IMPLIED.

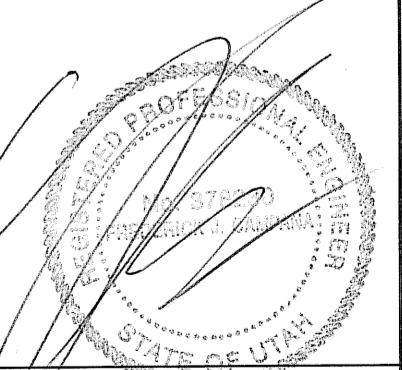

ISSUE	REV.	DESCRIPTION	DATE	DRN. DES.
A		CONFIRMATION	05.20.08	FFF/LDD

**RIGID BUILDING SYSTEMS**  
18933 Aldine Westfield  
Houston, Tx. 77073  
Phone : (281) 443-9065  
Fax : (281) 443-9064

DESCRIPTION	DETAIL PAGE
CUSTOMER	ELEGANTE ENTERPRISES, INC.
END USER	PAINTERS SERVICE CENTER
END USE	OFFICE/SERVICE BAYS
LOCATION	1600 HILTON DR. ST. GEORGE, UT 84770
DRN. BY: FFF	DATE: 05/20/08
JOB NO.: 28268-B	SCALE: N.T.S.
	DWG. NO.: E10 OF
	ISSUE: A